



INDUSTRIAL BALL VALVES

SERIES 7100

SERIES 8100

SERIES 7200

SERIES 8300

SERIES 7400

SERIES 8400

SERIES 8000

SERIES 8500

INSTALLATION, OPERATION AND MAINTENANCE MANUAL

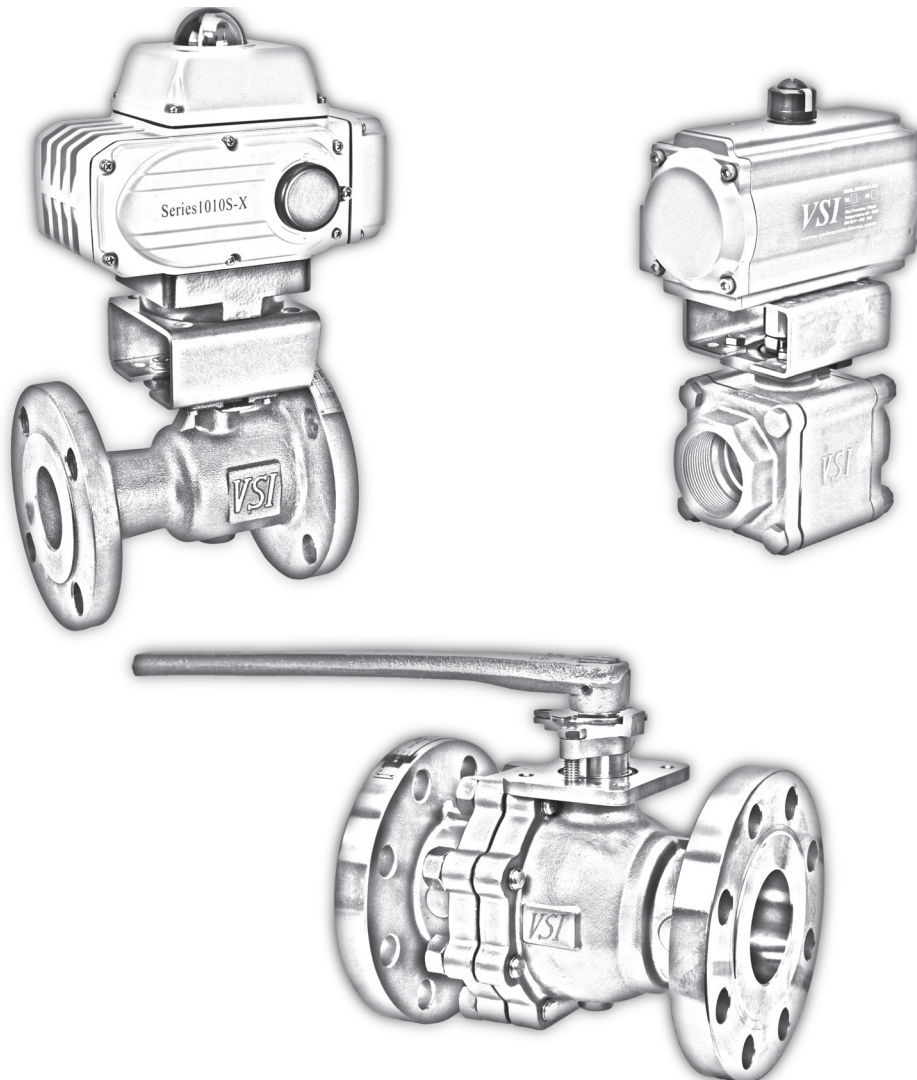



TABLE OF CONTENTS

INSTRUCTIONS	3
SAFETY MESSAGES	3
INSTALLATION	4
FIGURE 1 BOLT TIGHTENING	5
OPERATION	6
SEAT REPLACEMENT	6
TROUBLESHOOTING GUIDE	8
PARTS CROSS SECTION	9

INSTRUCTIONS:

These instructions are for the VSI industrial ball valve range and those who will be responsible for the installation, operation and maintenance of the valves. There are several configurations however all function with the same principal of a round port ball with body mounted seats.

SAFETY MESSAGES:

All Safety messages in this manual are flagged with an exclamation symbol and the word Danger, Caution or Warning. These messages indicate procedures that must be followed exactly to avoid equipment damage, personal injury or death.



WARNING!

Personnel involved in the installation or maintenance of valves should be alert to potential emissions of pipeline material and take appropriate safety precautions. Always wear suitable protection when dealing with hazardous pipeline material, also handle valves that have been removed from service with suitable protection from any potential pipeline material in the valve.

INSPECTION:

Your VSI Ball Valve has been packaged to provide protection during shipping. However, it is still possible to be damaged during shipping. Please inspect the unit for damage upon arrival and file a claim if damage is apparent.

PARTS:

Order parts from your Valve Solutions sales representative. Please include the serial number, located on the valve tag, when ordering parts.



WARNING!

Read all applicable instructions and directions prior to any maintenance, installation or troubleshooting.

SECTION 1 - INSTALLATION

WARNING!

Valves are a significant component of any piping system. Failure due to faulty installation, improper operation or maintenance in such systems could result in damage, down time, and costly repairs. Many problems can be traced to improper installation, operation or maintenance procedures.

Sec 1.1 Unloading

Inspect valves upon receipt for any damage that may have occurred during shipping, as well as conformance with quantity, configuration and description from the shipping order. When removing valves from the shipping containers, be careful not to lift the valves using slings or chain around the operating shaft, actuator, or thru the waterway. Instead, lift the valves with eye bolts or rods thru the flange holes.

Sec 1.2 Storage

The valves should be stored on a pallet or “skid” in a clean, dry warehouse. If the valves must be stored outside, the following should apply:

1. Valves must be kept off the ground high enough to avoid standing water.
2. Cover the valves with a water repellent cover (not included with the valve), to prevent dirt and water from compromising the valve body or seat.

Sec 1.3 Installation of Threaded Valves

1. Threaded valves may be installed with or without the use of unions. Three piece valves allow installation without unions while still allowing replacement of seats if pipe spreaders are used. It is not possible to service the seat of two piece valves without the use of a union or other installation considerations.
2. The use of a thread sealant is recommended. Consult with the installation engineer to specify the appropriate sealant for the valve and pipe material.
3. Only apply the wrench being used to install the valve on the end being tightened. Never apply torque to the opposite end - the valve may experience deformation or loosening of the body seal.
4. Do not use the body threads or body bolts to pull the pipe ends together or into alignment, leakage may occur.
5. The force/torque required to thread the valve onto the pipe will be dependent on the valve material, pipe material, pipe thread machining class, thread sealant, lubricant, and/or other considerations. It is not possible to give a single value for good sealing. Care should be taken at all times.
6. Cycle the valve open then closed to ensure proper operation

Sec 1.4 Installation of Butt or Socket Welded Valves

1. Fix valve in its final position using clamps, magnets, or other fixturing as required.
2. Tack weld the valve to the pipe at four points on each end of the valve.
3. With the valve in the open position loosen and remove all the bolts that hold the end caps to the main valve body.
4. Remove the main body leaving the end caps tacked to the pipe ends
5. Remove the seats and the ball from the main body

6. Reinstall the main body between the end caps. Reinstall and slightly tighten all the bolts that hold the end caps to the main valve body.

WARNING!

It is extremely important that welds not be performed on the valve with the seats installed. Valves should be completely assembled without seats when welds are performed to ensure that valve body and end caps are perfectly aligned.

7. Finish weld both end caps onto the pipe
8. When cool, remove the valve main body from between the end caps and clean completely the interior of the valve body, the interior of the welds performed, and the exterior of all components. Use brass wire brushes, solvents, and compressed air as necessary.
9. Reinstall the ball and seats into the main body and reinstall between the end caps following the seat replacement instructions within this manual.
10. Cycle the valve open then closed to ensure proper operation

Sec 1.5 Installation of Flanged Valves

1. Do not use the body bolts or flange bolts to pull the pipe ends together or into alignment, leakage may occur.
2. Spread the flanges to exceed the valves face to face dimension.
3. Carefully place the valve into place between the flanges. Take care that the flange seating surface and the valve seats are not scratched.
4. Insert appropriate gaskets and ensure they are positioned properly
5. Line up, center and secure the valve between the flanges using the desired bolts or studs. Use proper bolting sequence as shown in Figure 1.
6. The torque required for flange bolts will be dependent on the valve class, gasket material/design, bolt class, thread lubricant, and/or other considerations. Users should consult their gasket supplier for recommended flange bolting torque.
7. Cycle the valve open then closed to ensure proper operation.

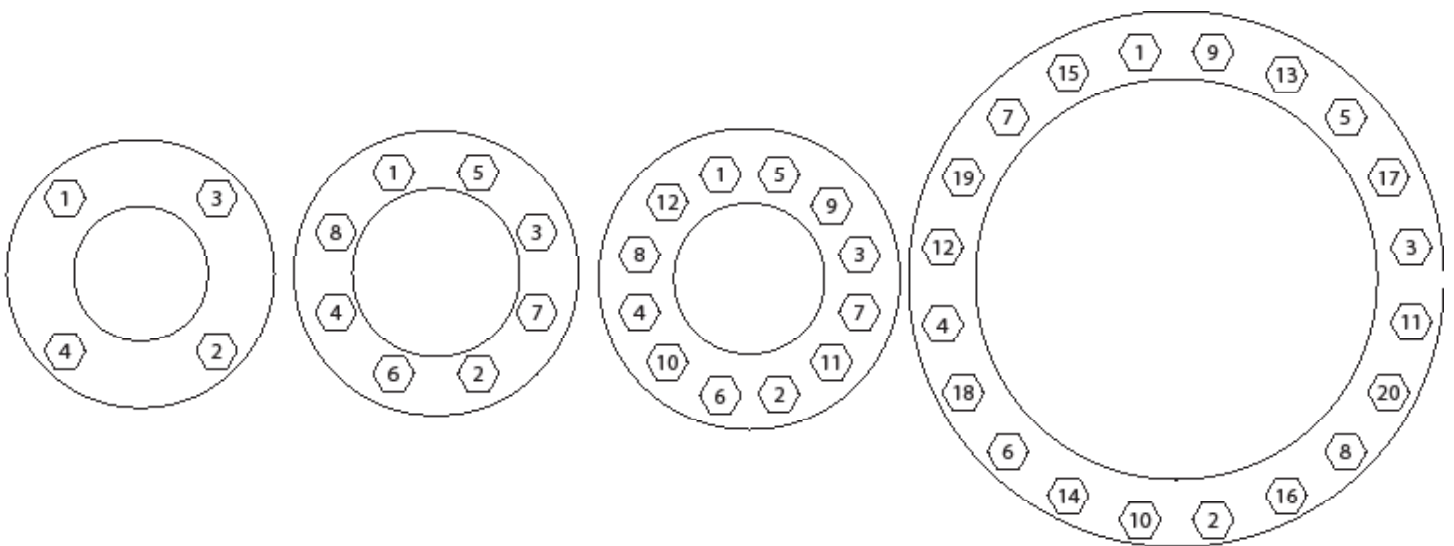

FIGURE 1: BOLTING SEQUENCE

SECTION 2 - OPERATION

Clockwise rotation of the valve shaft closes the ball for 2-way valves. The valve is fully closed when the lever is perpendicular to the pipe. For automation purposes the valve is fully closed when the flats on the valve shaft are perpendicular to the pipe.

Three way valves are available in either T-Port or L-Port configurations. It is important to reference the tag for the type of valve supplied. Three way valves feature a square shaft that allows the lever/operator to be installed in any orientation. The Series 7300 has engraved into the top of the shaft the flow direction of the valve. The Series 8300 has no markings for flow direction.

For all valves either a lever or other operator as needed for the projects is connected to the valve shaft, and positions the ball at the closed, open, or intermediate position. Any adjustable stops for the open and closed positions of the valve are pre-set to match the valve's open and closed positions. Please see the actuator instructions for any information on adjusting the end stops on the actuator.

Levers feature a locking mechanism in the open and closed position. Lift the locating lock and rotate the lever in the desired rotation.

SECTION 3 - MAINTENANCE

Routine maintenance or lubrication is generally not required.

Sec 3.1 Packing

Visually inspect the packing area for leaks yearly and tighten packing gland if leakage is observed. If leaking packing cannot be corrected by tightening gland bolts replacement of packing is necessary.

1. Remove line from service and isolate valve as necessary
2. Remove actuator following appropriate actuator manual.
3. Loosen and remove gland. Inspect for damage and replace if necessary.
4. Using a packing removal tool or pick remove the packing rings taking care not to scratch or damage the packing housing of the valve body or the valve shaft.
5. Carefully clean the packing housing with compressed air and brass brushes
6. Insert the new packing set, only using compatible grease if necessary.
7. Reinstall the gland tightening only until snug.
8. Return valve to service and inspect packing for leakage. If leakage is observed tighten gland 1/2 turn at a time until leakage ceases.

Sec 3.2 Cycle

Cycle valve open/close at least once every 3 months to prevent media buildup in valve.

SECTION 4 - SEAT REPLACEMENT

Sec 4.1 Series 8000, 8100, and 8300

The seat is not user replaceable in the Series 8000, 8100, or 8300. If leakage past the seat is suspected of these valves inspect the valve and replace if necessary.

Sec 4.2 Series 7400, 8400, and 8500

1. Loosen the bolts that hold the end caps to the main body.
2. If the installation features a pipe union, loosen and remove the lock ring. Gently remove the pipe section and main valve body.
3. If the installation does not have a pipe union a pipe spreader must be used. Spread the pipe sections enough to remove the main valve body.
4. Using a pick or packing tool remove the valve seats and the body seals from the main body.
5. Inspect ball face for scratches that may damage the new seat. Replace the ball if necessary.
6. Clean the seat grooves in both the valve main body and end caps.
7. Install the new seats and body seals in the main body.
8. Reinstall the main body assembly between the end caps and pipe.
9. Reinstall the bolts that hold the end caps to the main body. Tighten gradually all bolts to the final torque shown in Table 1.

Tightening Torques for end cap screws								
Valve Size (NPS)	1/2"	3/4"	1"	1-1/4"	1-1/2"	2"	3"	4"
Bolt Torque (inlbs)	140	210	210	550	550	550	996	996

Table 1

Sec 4.3 Series 7100

1. Remove the valve from the piping
2. Turn the valve to the closed position.
3. Using a specialized tool provided by VSI loosen the seat cap and remove it from the valve body by turning counterclockwise. If the cap side seat does not pull from the valve with the cap remove it from the valve body.
4. Using a wooden or plastic dowel push out the ball from the main body.
5. Remove the body side seat from the valve.
6. Clean the seat grooves in both the valve main body and seat cap. Clean the threads on the seat cap and the main body.
7. Install a new seat in the body
8. Reinstall the ball into the body in the closed position aligning the groove in the ball with the tab on the valve stem.
9. Install a new seat in the seat cap.
10. Reinstall the seat cap by turning clockwise until flush with the main body.
11. Reinstall the valve.

Sec 4.4 Series 7200

1. Remove the valve from the piping
2. Turn the valve to the closed position.
3. Loosen and remove the valve body bolts
4. Remove the seat cap. If the cap side seat does not pull from the valve with the cap remove it from the valve body.
5. Using a wooden or plastic dowel push out the ball from the main body.
6. Remove the body side seat from the valve.
7. Clean the seat grooves in both the valve main body and seat cap.
8. Install a new seat in the body
9. Reinstall the ball into the body in the closed position aligning the groove in the ball with the tab on the valve stem.
10. Install a new seat in the seat cap.
11. Place the seat cap back onto the body and reinstall the body bolts. Tighten gradually all bolts to the final torque shown in Table 2.

Tightening Torques for end cap screws							
Valve Size (NPS)	1/2"	3/4"	1"	1-1/4"	1-1/2"	2"	2-1/2"
Bolt Torque (in-lb)	140	140	210	210	550	550	550

Valve Size (NPS)	3"	4"	6"	8"	10"	12"
Bolt Torque (in-lb)	550	550	1000	1000	1450	1450

Table 2

SECTION 5 - Troubleshooting Guide

PROBLEM	CAUSE	REMEDY
External leak at connection	Improper/cross threading of NPT connection	Remove valve, inspect threads and repair/replace as needed
	Leaking past gasket of flanged connection	Ensure bolting is tightened to gasket manufacturer's recommendations
	Leakage at weld joint	Repair weld as necessary
External leak at stem seal	Packing normal wear	Tighten packing gland or nut
	Defective or overly work packing	Replace packing
Leakage past valve seat	Ball obstructed	Check that valve is in its full closed position. If not remove valve and check for solids blocking the ball port
	Broken stem	Replace valve
	Seat retainer/carrier loose	Tighten seal carrier or end cap according to the instructions in this manual
	Worn or damaged seat	Replace the valve seats according to the instructions in this manual
Valve will not operate open/close	Ball obstructed	Check that valve is in its full closed position. If not remove valve and check for solids blocking the ball port
	Seal retainer/carrier too tight	Loosen seal carrier or end cap and tighten to specifications in this manual
	Chemical or physical attack of valve	Check valve materials of construction and confirm compatibility with service media and operating temperature
	Actuator not properly adjusted or damaged	Consult manual for actuator and adjust, repair, or replace as needed

INSTALLATION, OPERATION AND MAINTENANCE

VSI INDUSTRIAL BALL VALVES



SERIES 8000

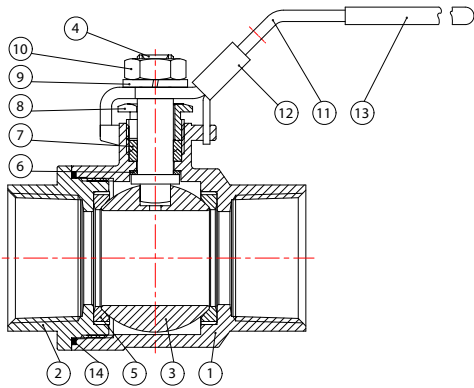

ITEM	PART
1	BODY
2	CAP
3	BALL
4	STEM
5	SEAT
6	THRUST WASHER
7	STEM PACKING

ITEM	PART
8	GLAND NUT
9	SPRING WASHER
10	NUT
11	HANDLE
12	LOCKING PAD
13	HANDLE COVER
14	BODY SEAL

SERIES 8100

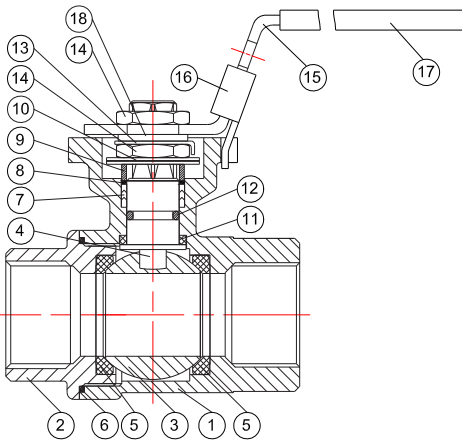

ITEM	PART
1	BODY
2	CAP
3	BALL
4	STEM
5	SEAT
6	BODY SEAL
7	STEM PACKING
8	WASHER
9	PACKING GLAND
10	SPRING WASHER

ITEM	PART
11	THRUST WASHER
12	O-RING
13	LOCK WASHER
14	PACKING NUT
15	HANDLE
16	LOCKING PAD
17	HANDLE COVER
18	WASHER
19	STOP SCREW

SERIES 8300

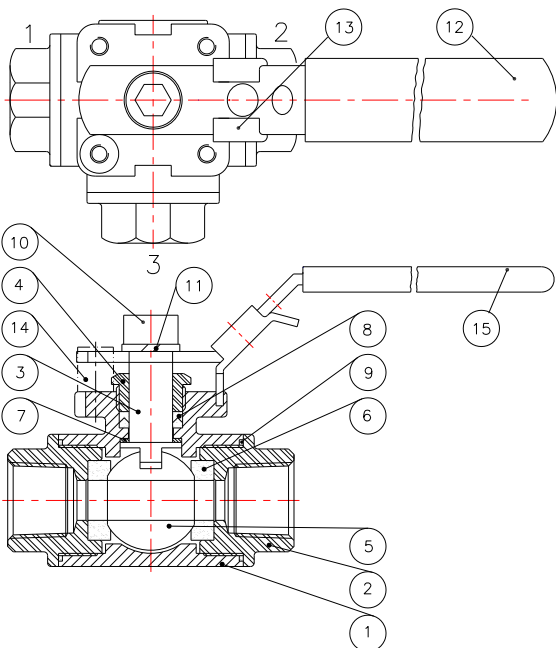

ITEM	PART
1	BODY
2	CAP
3	STEM
4	GLAND NUT
5	BALL
6	SEAT
7	THRUST WASHER
8	STEM PACKING

ITEM	PART
9	BODY SEAL
10	BOLT
11	WASHER
12	HANDLE
13	LOCKING PAD
14	STOP SCREW
15	HANDLE COVER

SERIES 7400

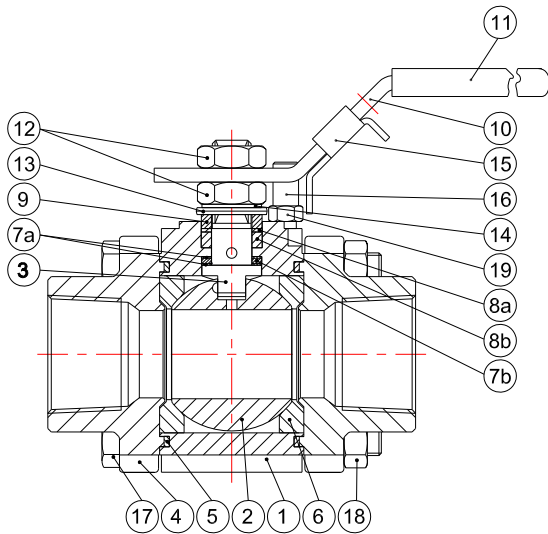

ITEM	PART
1	BODY
2	BALL
3	STEM
4	CAP
5	BODY SEAL
6	SEAT
7a	THRUST WASHER
7b	THRUST WASHER
8a	STEM PACKING A
8b	STEM PACKING B
9	PACKING GLAND

ITEM	PART
10	HANDLE
11	HANDLE COVER
12	PACKING NUT
13	SPRING WASHER
14	LOCK WASHER
15	LOCKING PAD
16	STOP SCREW
17	BODY BOLT
18	BODY NUT
19	NUT

SERIES 8400/8500

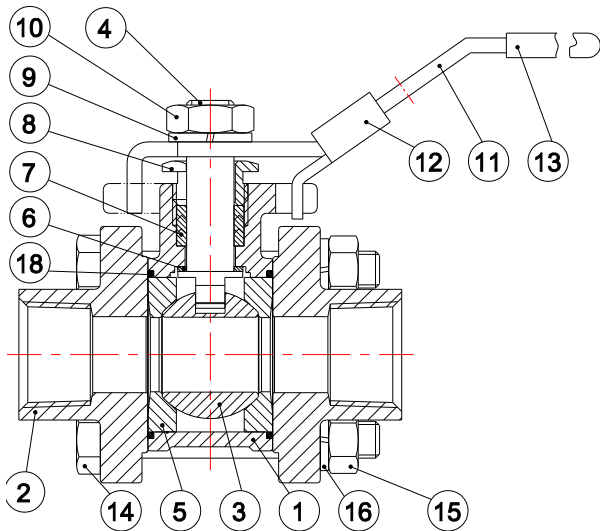

ITEM	PART
1	BODY
2	CAP
3	BALL
4	STEM
5	SEAT
6	THRUST WASHER
7	STEM PACKING
8	GLAND NUT
9	SPRING WASHER

ITEM	PART
10	NUT
11	HANDLE
12	LOCKING PAD
13	HANDLE COVER
14	BODY BOLT
15	BODY NUT
16	LOCK WASHER
NS	STOP SCREW
18	BODY SEAL

INSTALLATION, OPERATION AND MAINTENANCE
VSI INDUSTRIAL BALL VALVES



SERIES 7100

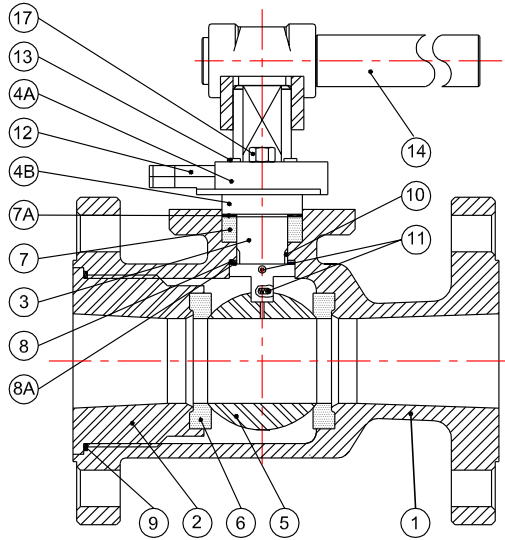

ITEM	PART
1	BODY
2	CAP
3	STEM
4A	PACKING GLAND
4B	GLAND RING
5	BALL
6	SEAT
7	STEM PACKING A
7A	STEM PACKING B

ITEM	PART
8	THRUST WASHER
8A	THRUST WASHER
9	BODY SEAL
10	BEARING
11	ANTI-STATIC DEV.
12	TRAVEL STOP
13	SNAP RING
14	HANDLE
17	GLAND BOLT

*ILLUSTRATED VALVE REPRESENTS 3" - 10". SEE DETAIL PRODUCT DATA FOR OTHER SIZES

SERIES 7200

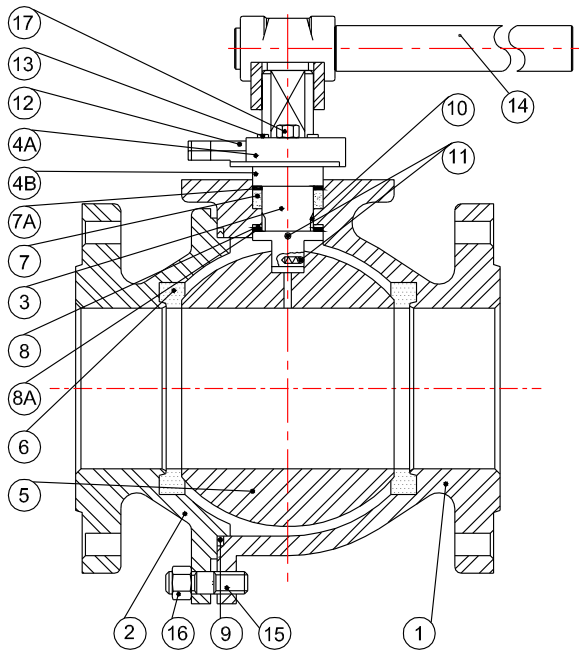

ITEM	PART
1	BODY
2	CAP
3	STEM
4A	PACKING GLAND
4B	GLAND RING
5	BALL
6	SEAT
7	STEM PACKING A
7A	STEM PACKING B
8	THRUST WASHER

ITEM	PART
8A	THRUST WASHER
9	BODY SEAL
10	BEARING
11	ANTI-STATIC DEV.
12	TRAVEL STOP
13	SNAP RING
14	HANDLE
15	BODY STUD
16	NUT
17	GLAND BOLT

*ILLUSTRATED VALVE REPRESENTS 2.5" - 8". SEE DETAIL PRODUCT DATA FOR OTHER SIZES