

FIGURE A

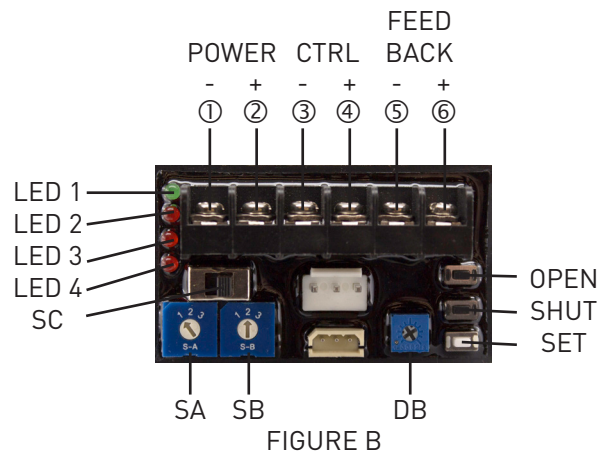

FIGURE B

The SF-LB control pack, when shipped together with a Series 1000-X actuator, is factory calibrated and set for 90° rotation no adjustment is necessary. However, if you are replacing the SF-LB or the factory settings do not conform to your actuator/valve application, adjustment may be required.

INITIAL SETUP

If not connected to the actuator, install the SF-LB by plugging the two cables from the actuator into the unit. Connect the appropriate power to terminals 1&2. Connect the control signal to terminals 3&4 and note that the **polarity must be positive (+) and negative (-)**.

If feedback is being used, connect the wiring to terminals 5&6. The SF-LB provides position feedback of 4-20mA.

At this point, the Green LED "L1" should be illuminated. If Red LED "L2" is illuminated then the control signal is faulty or SC switch in Figure B above is not set correctly for your control signal. Ensure the SC switch is set for your input control signal (2-10V or 4-20mA). Once there are no Red LED's illuminated, your actuator is ready to operate. Increase/decrease your control signal to confirm proper operation. See the chart below for failure mode conditions on the SF-LB control pack.

SF-LB CONTROL PACK LED'S		
LED	CAUSE DESCRIPTION	REMEDY
LED-1 (GREEN)	POWER IS PRESENT ON INPUT TERMINALS	NORMAL OPERATION
LED-2 (RED)	IMPROPER CONTROL SIGNAL, NOT PRESENT OR INCORRECT POLARITY	CHECK SC SWITCH TO ENSURE PROPER CONTROL SIGNAL(2-10v/4-20mA) - CHECK TO ENSURE SIGNAL IS PRESENT
LED-3 (RED)	POTENTIOMETER IS NOT CALIBRATED WITH ACTUATOR	RECALIBRATION PROCEDURE IS IN COMPLETE IOM (CALL FOR ASSISTANCE)
LED-4 (RED)	OVER-TORQUE CONDITION PRESENT - VALVE BINDING, OR MANUAL OVERRIDE HAS BEEN USED AND ACTUATOR IS OUT OF SYNC WITH CONTROLLER	CHECK TO MAKE SURE VALVE IS NOT BINDING. RESET CONTROL PACK BY ROTATING SA FROM 1 TO 2 AND BACK TO 1, OR REMOVE/REPLACE POWER TO THE UNIT

NOTE: THE ACTUATOR WILL NOT OPERATE UNLESS THE AUTO/MANUAL OVERRIDE PUSH BUTTON IS DEPRESSED. POWER WILL ALSO NEED TO BE RESET TO THE CONTROL PACK TO RESUME OPERATION.



FIGURE C



FIGURE D

MANUAL OVERRIDE PUSH BUTTON

The Series 1000-X units are equipped with a manual override power button which disconnects the power internally to the motor - Figure C above. This enables manual operation of the actuator using the provided hand crank or the optional hand wheel. The LED's on the SF-LB will still be illuminated in manual mode. **If manual operation of the unit is performed, the unit will need to be re-set either switching SA from 1 to 2 and back to 1 again or removing and replacing power to the unit.**

SWITCH SETTINGS

SA is used for setting the “direct acting” (2V/4mA=closed and 10V/20mA=open) or “reverse acting” (2V/4mA=open and 10V/20mA=closed) rotation of the actuator. Direct acting is setting (1) and reverse acting is setting (3). SA is also used for placing the actuator in “set mode” – setting (2). Set mode is used to manually stroke the actuator by pressing the “open” or “shut” button and for setting the stroke limit position of the actuator (see below). SB is used for setting the fail position of the actuator in case of a control signal loss only, **not** power loss. Figure D above shows the side of the control pack with settings for SA and SB. **The SF-LB units are factory set to SA-1 and SB-2 “direct acting” and fail “in place”.** The SC switch is used for selecting the input control signal (2-10V or 4-20mA). DB is used for setting the sensitivity on the “dead band” – rotate clockwise for less sensitive, rotate CCW for more sensitive. Units are factory set to mid-range sensitivity.

SETTING THE POSITION LIMITS

Refer to FIG B for button/switch details. Position limits are factory set to 90° rotation. If desired, the position limits can be re-configured to rotate less than 90°. To re-set the position limits of the unit, **SA should be placed in “set mode” by switching to “2”.** At this point, the “open” or “shut” buttons can be pressed to stroke the actuator. To set the closed limit, push the “shut” button or manually rotate actuator to desired position and make sure the control signal is applied with the proper V or mA required for close, e.g. 2V or 4mA. While holding the white “set button”, depress the “shut” button and hold until LED 2 flashes then release both. The closed limit is now set. To set the open limit, push the “open” button or manually rotate actuator to desired position and make sure the control signal is applied with the proper V or mA required for open, e.g. 10V or 20mA. While holding the white “set button”, depress the “open” button and hold until LED 2 flashes then release both. The open limit is now set. SA can now be set back to (1) direct acting or (3) reverse acting. Increase/Decrease control signal to confirm proper operation.

NOTE: ACTUATOR IS EQUIPPED WITH MECHANICAL STOPS. THESE ARE FOR SAFETY ONLY AND SHOULD NOT BE USED TO SET THE POSITION LIMITS ON THE ACTUATOR.

For the complete IOM on the Series 1000-X actuators, please visit www.valvesolutions.com or if technical support is needed during setup or troubleshooting, please call 770-740-0800.